



# Breas Clearo User Manual

010076 rev. 2.2 en-US

Clearo, User's



ENGLISH (US)

Clearo User Manual



Breas Medical AB, Företagsvägen 1, SE-435 33 Mölnlycke, Sweden  
Phone +46 31 86 88 00  
Order +46 31 86 88 20, Technical Support +46 31 86 88 60  
Fax +46 31 86 88 10, www.breas.com, Date: 2026-02-03 | 34776



7 321820 100767



# Table of Contents

1	Introduction.....	5
1.1	Icons.....	5
1.2	What is the Clearo? .....	6
1.3	Indications for Use.....	6
1.4	Intended Patient Population .....	6
1.5	Multiple Use.....	6
1.6	Environment of Use .....	6
1.7	Patient Interfaces.....	7
1.8	Software Information .....	7
1.8.1	Cybersecurity.....	7
1.8.2	Events Logs .....	7
1.9	Contraindications to Use.....	7
1.10	Considerations before Use .....	8
1.11	Undesirable Side Effects.....	8
1.12	About this Manual .....	9
1.13	Manufacturer Contact Information.....	9
2	Safety information.....	10
2.1	General User Precautions .....	10
2.2	Electrical Safety .....	12
2.3	Environmental Safety .....	12
3	Product Description .....	14
3.1	Main Components .....	14
3.2	Front Panel.....	15
3.3	Side Panels .....	16
3.4	Back Panel.....	17
3.5	Equipment Designations and Safety Labels .....	17
4	Preparing the Clearo for Use.....	20
4.1	Checking the Device before Use .....	20
4.2	Placing the Clearo Ready for Use .....	20
4.3	Connecting to AC Power (Mains).....	20
4.4	Inspecting the Clearo before Use .....	21
5	How to Use the Clearo.....	22
5.1	Connecting the Patient Circuit .....	22
5.2	Circuits .....	22
5.3	Turning the Device On/Off .....	22
5.4	On-Screen Symbols.....	23
5.5	General Functionality and Display.....	24
5.6	The Main Menu .....	25
5.7	Treatment Settings .....	28
5.7.1	Selecting a Mode.....	28

5.8	Profiles .....	28
5.8.1	Loading a Treatment Profile .....	28
5.9	Starting and Stopping Treatment .....	29
5.9.1	Starting a Manual Mode Treatment .....	29
5.9.2	Starting an Automatic Treatment .....	30
5.10	Recruitment Breaths .....	30
5.11	View Treatment Waveforms .....	31
5.12	Use with the SpO <sub>2</sub> Sensor .....	31
5.13	Accessing User Data .....	32
5.14	Using Batteries .....	32
5.15	Using the Hand Control .....	34
5.16	Transferring Data .....	34
6	Alarms .....	36
6.1	Alarm Function .....	36
6.2	Alarm Indication .....	36
6.3	Alarm Reset .....	36
6.4	Alarms and Messages Descriptions .....	37
6.4.1	High Pressure Alarm .....	37
6.4.2	Power Source Changed Alarm .....	37
6.4.3	Power Fail Alarm .....	37
6.4.4	Pressure Measurement Fault Alarm .....	38
6.4.5	Pressure Sensor Fault Alarm .....	38
6.4.6	Battery Exhausted Alarm .....	38
6.4.7	SpO <sub>2</sub> Sensor Disconnected Alarm .....	39
6.4.8	Low Battery Power Alarm .....	39
6.4.9	Treatment too Long Message .....	39
6.4.10	MI-E Mode Selected Message .....	40
6.4.11	Treatment has Finished Message .....	40
6.4.12	SPO <sub>2</sub> Connected Message .....	40
6.4.13	Treatment Not Saved Message .....	40
6.5	Machine Fault Message Descriptions .....	41
6.5.1	Internal Battery Health Bad .....	41
6.5.2	Over Temperature .....	41
6.5.3	Low Alarm Battery Fault .....	41
6.5.4	Mains Power Fault .....	42
6.5.5	Blower Driver Fault .....	42
6.5.6	Valve Zero Fault .....	42
6.5.7	Valve Drive Fault .....	43
6.5.8	Alarm PIC Communications Fault .....	43
6.5.9	Internal Module Communications Fault .....	43
6.5.10	Blower Fault .....	44

	6.5.11	Blower Speed Fault .....	44
	6.5.12	Valve Position Fault .....	44
	6.5.13	Valve Current Fault .....	45
	6.5.14	Blower Current Fault and/or Blower Speed Fault .....	45
	6.5.15	Blower Speed Fault .....	45
	6.5.16	Blower Control Fault and/or Blower Fault .....	46
	6.5.17	Blower control Fault .....	46
	6.5.18	Valve Current Fault .....	46
	6.5.19	Valve Drive Fault .....	47
	6.5.20	Valve Position Fault .....	47
	6.5.21	Alarm Battery Fault .....	47
7		Cleaning and Maintenance .....	48
	7.1	Cleaning the Clearo .....	49
	7.2	Air Inlet Filters Maintenance .....	49
	7.3	Change of Patient .....	50
	7.4	Essential and Regular Maintenance Control .....	50
	7.5	Service and Repair .....	51
	7.6	Storage .....	51
	7.7	Transport .....	51
	7.8	Disposal .....	52
8		FAQs and Troubleshooting .....	53
	8.1	FAQs .....	53
	8.2	Troubleshooting .....	53
9		Technical Specifications .....	54
	9.1	Parameters Specifications .....	54
	9.2	Electrical Information .....	54
	9.3	Alarm Sound Specifications .....	55
	9.4	Environmental Operating Conditions .....	55
	9.5	Dimensions .....	55
	9.6	Emissions and Immunity Declaration .....	56
	9.6.1	Clearo Essential Performance .....	56
	9.6.2	Compliance of Standards .....	56
	9.6.3	Electromagnetic Immunity .....	56
	9.6.4	Electromagnetic Emission .....	58
	9.6.5	Frequencies of portable and mobile transmitters for which the recommended separation distance is 30 cm (12 inches) .....	59
	9.6.6	Recommended separation distances between portable and mobile RF communications equipment and the Clearo .....	59
	9.6.7	Recommended separation distances between external power conductors and the Clearo .....	60
10		Accessories .....	61
	10.1	Package Content .....	61

10.2	Optional Accessories .....	61
A	Patient Settings .....	63
B	Glossary of Abbreviations and Terms.....	64
	Index .....	65

# 1

## Introduction

### WARNING!

Use Clearo only as directed by a physician or healthcare provider.

#### Risk of Personal Injury

The Clearo must only be used:

- For the intended treatment in accordance with this manual and with the instructions given by the responsible clinical personnel.
- In accordance with the operating conditions specified in this manual.
- In original and unmodified shape and only with compatible accessories.

Every other use may lead to risk of personal injury!

### CAUTION!









Read this manual thoroughly so that you completely understand how the Clearo is operated and maintained before taking it into use, to ensure correct usage, maximum performance and serviceability. Non-professional caregivers (e.g. family members) should consult the medical equipment provider's respiratory therapist if they have any questions about the function, proper use, operation, service or maintenance of the Clearo.

U.S. Federal law restricts this device to sale by or on order of a physician.

## 1.1

### Icons

Within this manual you will see the following icons. The meaning of each icon is explained in the table below:

Icon	Explanation
	<b>Warning!</b> Risk of death or personal injury.
	<b>Warning!</b> Risk of Cross-contamination.
	<b>Warning!</b> Risk of electric shock.
	<b>Warning!</b> Flammable material, risk of fire.
	<b>Caution!</b> Risk of equipment damage, loss of data, extra work, or unexpected results.
	MR Unsafe. The device should not enter a magnetic resonance (MR) environment, such as an MRI scanner room.
	<b>Note</b> Information that may be valuable but is not of critical importance, tips.
	<b>Reference</b> Reference to other manuals with additional information on a specific topic.

## 1.2 What is the Clearo?

The Clearo is an airway clearance device that provides the following therapeutic options:

- **Mechanical Insufflation-Exsufflation (MI-E).** MI-E simulates a natural cough through two distinct phases:
  1. Insufflation (Inhalation Phase):

The device delivers a breath under positive pressure, expanding the lungs in a manner similar to taking a deep breath.
  2. Exsufflation (Exhalation Phase):

This is immediately followed by a rapid switch to negative pressure, which quickly sucks air out of the lungs, replicating the forceful exhalation of a natural cough.



### NOTE

This product does not contain latex in any of its components or accessories.

## 1.3 Indications for Use

Clearo is indicated for use on adult or pediatric patients unable to cough or clear secretions effectively. It may be used either with a facemask or mouthpiece, or with an adapter to a patient's endotracheal or tracheostomy tube. The device is intended to be used in the hospital, institutional environment or in the home.

## 1.4 Intended Patient Population

The device is intended for use within a hospital, institutional environment, or in the home. Individuals who may benefit from the use of the Clearo include any patient with an ineffective cough due to;

- Muscular Dystrophy
- Amyotrophic lateral sclerosis (ALS)
- Myasthenia Gravis
- Poliomyelitis
- Other Neurologic Disorders
- Spinal Cord Injury

## 1.5 Multiple Use

This is a multiple patient multiple use device. If it should be used by multiple patients, a low resistance bacterial filter shall be used between the patient air outlet and the patient circuit. See the instructions in 7.3 *Change of Patient*, page 50 before assigning it to a new patient.

## 1.6 Environment of Use

Clearo is intended to be used in homes, institutions and hospitals.

Clearo is not intended to be used together with portable applications such as wheelchairs, gurneys or personal family vehicles.

Clearo is not intended to be used in an aircraft.

Clearo is not intended for use during emergency transports.

## 1.7 Patient Interfaces

The Clearo device can be used for MI-E invasively via an endotracheal tube (ET) or tracheostomy. It can also be used non-invasively with either a facemask or a mouthpiece.

## 1.8 Software Information

### 1.8.1 Cybersecurity

- The Clearo – The Clearo has no network connection and is not a ‘cyber device’. It does not require a user account or password for its intended use.
- The Clearo has two interfaces for sending and receiving data:
  - An SD card interface, for downloading compliance data and for saving and loading device settings. See 5.16 *Transferring Data*, page 34.
  - An USB port interface, for use by authorized service personnel to apply firmware updates and perform service checks.

These interfaces are active only when using the related function.

- The Clearo software can be updated or reinstalled by authorized service personnel only. Return the device to an authorized service provider to obtain software updates. Breas announces software updates to authorized service providers through Service bulletins available on the Breas extranet.

For additional cybersecurity information and precautions, contact Breas Medical Technical Support to obtain a copy of Clearo MDS2 or Manufacturer's Disclosure Statement for Medical Device Security.

### 1.8.2 Events Logs

Events are logged to a detailed log for of clinical parameters, and a usage log for alarms, settings and other non-clinical events. The detailed log holds at least 24 hours of data and the usage log is for 90 days. When the logs get full, the oldest data is overwritten by the new one (circular logs). The logs are maintained in the internal memory during power failure and can also be transferred to a memory card.

## 1.9 Contraindications to Use



### WARNING!

Before using the Clearo, ensure the patient does not have any of the conditions listed in this section.

The patient should be reviewed regularly to ensure that their condition has not altered. If the user of the Clearo develops one of the below contraindications, contact your referring Clinician before continuing to use the Clearo:

- Patients with a history or risk of bullous emphysema.
- Patients with a history or are susceptible to pneumothorax or pneumo-mediastinum.
- Patients with cardiovascular instability.
- Patients with tracheoesophageal fistula.
- Recent or existing barotrauma.
- Spinal instability.
- Acute pulmonary oedema.
- Active, untreated tuberculosis.
- Active haemoptysis and frank haemoptysis.
- Recent oesophageal surgery.
- Increased intracranial pressure.
- Acute lung injury.
- Facial, skull or oral trauma and or surgery.
- Fractured ribs with flail segments.
- Pulmonary air leak
- Recent pneumonectomy
- Pulmonary hemorrhage
- Myocardial infarction

## 1.10 Considerations before Use



### **WARNING!**

Do not use the Clearo with patients with the below conditions without specific instructions from your referring clinician.

A risk assessment and guidance should be provided. If the patient develops any of the below symptoms/conditions, you must consult the referring clinician before continuing use of Clearo.

- Bulbar insufficiency.
- Nausea or risk of vomiting.
- Gastrointestinal feed.
- Changes in symptoms or effectiveness of the treatment.

## 1.11 Undesirable Side Effects

If undesirable side effects are witnessed or reported, treatment should stop immediately, and the referring or responsible physician must be notified. If treatment becomes ineffective at clearing secretions and augmenting a cough, please contact your referring physician/clinician or home care provider.

## 1.12 About this Manual



### **WARNING!**

Always read this manual in full before using the device or performing maintenance on the machine. This is to ensure correct and safe usage as well as maximum performance and serviceability.

### **Intended Audience**

This manual is intended for the patient and lay caregiver of a patient requiring medical use of the Clearo device. The manual comprises information on general use of the Clearo. Patients and lay caregivers may read this manual for reference purposes, after appropriate guidance from the responsible care provider.



- Clinical personnel or medical professionals should read the Clinical Manual to completely understand how the Clearo is operated and maintained before taking it into use, to ensure correct usage, maximum performance and serviceability.
- Service personnel may order the Clearo Service Manual that contains detailed technical information for maintenance, service, and repair.

## 1.13 Manufacturer Contact Information

### **Legal Manufacturer**



#### **Postal Address**

Breas Medical AB  
Företagsvägen 1  
SE-435 33 Mölnlycke Sweden

#### **Web Address**

[www.breas.com](http://www.breas.com)

#### **Email address**

[breas@breas.com](mailto:breas@breas.com)

#### **Phone**

+46 31 868800, Order: +46 31 868820, Technical support: +46 31 868860

#### **Fax**

+46 31 868810

### **Americas Sales and Support Information**

**Phone:** 1-855-436-8724 ext 110

**Fax:** 1-540-301-0881

**Sales and Orders Email:** [orderUS@breas.com](mailto:orderUS@breas.com)

**Tech Support Email:** [supportUS@breas.com](mailto:supportUS@breas.com)

## 2 Safety information

### 2.1 General User Precautions



#### **WARNING!**

Never use Clearo without the appropriate training. Please contact Breas Medical AB if training is required.

#### **Clearo must only be used:**

- For the intended treatment in accordance with this operating manual and with the instructions given by the responsible clinical personnel. Failure to do so may cause serious harm or injury to the patient.
- Under the direction and prescription of a physician, respiratory therapist, or other qualified persons.
- In accordance with the operating conditions specified in this operating manual.
- In the original and unmodified form and only with accessories specified or approved by Breas Medical AB
- If the patient is using the Clearo outside the hospital environment, there should always be a trained caregiver administering the therapy and monitoring the patient during and after therapy is carried out.
- When using the Clearo, suction and emergency resuscitation equipment shall be available.
- If the patient is admitted to a hospital or is prescribed any other form of medical treatment, always inform the medical staff that the patient has been prescribed a Clearo device for MI-E.
- Monitor the device while in use and stop providing treatment if the device malfunctions. Do not use the Clearo in the event of suspected damage to the device, unexplainable or sudden pressure, performance or sound changes during operation, or if the delivered air from the Clearo is abnormally hot or emits an odour. In these cases, contact the patient's responsible care provider for an inspection or Breas Medical AB.
- The Clearo may not work properly if any part has been dropped, damaged or submerged in water.
- Inadequate use of device or accessories may cause loss of treatment or decreased performance.
- The Clearo therapy settings must always be based on medical prescription and must be carried out by authorised clinical personnel only.
- Before use, inspect the Clearo, see 4.4 *Inspecting the Clearo before Use*, page 21.
- Ensure all accessories are compatible with the Clearo before use.
- Clinical personnel must read this manual before use.
- Handle the Clearo with care.
- Do not use the Clearo while in the carry bag.
- Do not use the Clearo with nitric oxide, helium or helium mixtures.
- Prolonged exposure of the SpO<sub>2</sub> sensor can cause contact injuries to skin.
- Nebulisation is not to be used with MI-E treatment.
- The Clearo is not intended to be used in line with a ventilator.





- Do not leave a patient unattended during any treatment.
- Always check the prescription, time and pressure settings before each treatment or between patients, as different modes and profiles may have different prescription settings.
- Patients known to have cardiac instability should be monitored for pulse and oxygen saturation very closely and therapy terminated if the patient shows sign of deterioration.
- The Clearo must only be serviced by personnel certified by Breas Medical AB.
- Use only power cords supplied by Breas Medical AB for this device.
- Ensure all cables for the device and accessories are away from the patient to avoid risk of accidental strangulation.
- If children are present, take measures to prevent choking hazards from small detachable parts, like the SD card.

### **WARNING!**



If the Clearo is to be used by several patients, a low resistance bacterial filter shall always be used between the patient air outlet and the patient circuit. Always use a new bacterial filter and patient circuit when using the device on a new patient.

### **CAUTION!**



- Always place the Clearo on a hard, clean surface, not on the floor.
- Always position the Clearo so that the air inlets are not obscured or blocked.
- Never use the device unless a bacteria filter is attached to the patient circuit.
- Keep the power cord in good order and away from heated surfaces.
- Device is not suitable for sterilization. For instructions on cleaning the Clearo see 7.1 *Cleaning the Clearo*, page 49.
- In the event of a power failure or malfunction: Remove the mask or patient interface, and ensure airways are clear.

### **NOTE**



Any serious incident that has occurred in relation to this device should be reported to the competent authority and the manufacturer.

## 2.2 Electrical Safety

To ensure electrical safety is maintained ensure the following procedures are met:

### WARNING!

- Do not use the device if it has a damaged cord, plug, or casing. Do not use the device if it is not working properly, has been dropped, or immersed in water. In any of these events, contact your local service centre.
- To avoid electrical shock, disconnect the electrical supply to the Clearo before cleaning. Do not immerse the Clearo into any fluids.
- Unplug the device if it comes into contact with water.
- If a multiple portable socket-outlet is used, it must not be placed on the floor.
- Do not use more than one multiple portable socket-outlet or extension cord.
- The operator must not touch accessible contacts of connectors and the patient simultaneously.
- The aspects of electromagnetic compatibility must be considered.
- The Clearo should not be used adjacent to or stacked with other equipment; if adjacent or stacked use is necessary, the Clearo should be observed to verify normal operation in that configuration.
- Mobile or transportable radio transmitters may interfere with the Clearo or performance of the display. See 9.6.6 *Recommended separation distances between portable and mobile RF communications equipment and the Clearo*, page 59 for more information.
- If a portable AC power supply is used, make sure that the voltage variations are within the operating limits of the Clearo. For AC operating limits, see 9.2 *Electrical Information*, page 54
- Use of accessories, transducers and cables other than those specified or provided by Breas could result in increased electromagnetic emissions or decreased electromagnetic immunity of this equipment and result in improper operation.



## 2.3 Environmental Safety

### WARNING!

Do not use the Clearo in environments where there are explosive gases or flammable anesthetic agents present.

### WARNING!

- Do not use the Clearo in any toxic environment.
- Do not use in the presence of high-frequency surgical equipment.
- The performance of the Clearo may deteriorate at ambient temperatures below -4°F (-20°C) and above 104°F (40°C). However, the treatment shall always be started in an ambient temperature warmer than 41°F (5°C).
- Do not expose the Clearo to rain or snowfall.





Do not use or store in the presence of strong electromagnetic fields such as an MRI environment. Use of the Clearo in an MRI environment may result in malfunction of the Clearo and pose unacceptable risk to the patient, medical staff, or other persons.

### CAUTION!

- Do not use the Clearo positioned in a warm place, such as direct sunlight or close to a radiator.
- Do not use the Clearo positioned near an open fire.
- The device complies with the electromagnetic compatibility (EMC) requirements of standards listed in the section 9.6.2 *Compliance of Standards*, page 56. Necessary measures should be taken in order to assure field levels exceeding 20 V/m are avoided, since this may impair the safety and performance of the Clearo.
- Measures should include but not be limited to:
  - Normal precautions regarding relative humidity and conductive characteristics of clothing in order to minimize the build-up of electrostatic charges. See 9.4 *Environmental Operating Conditions*, page 55 for detailed information.
  - Avoiding the use of radio emitting devices closer than 1 m to the Clearo. Radio emitting devices include cellular or cordless telephones, microwave ovens and high-frequency surgery apparatus.
  - Avoiding the use of Clearo in the presence of known electromagnetic interference (EMI) sources including radio frequency (RF) emitters (e.g. Radio frequency identification (RFID), surgical or therapeutic diathermy equipment). Please note some of these RF emitters may not be visible and the Clearo can potentially be exposed to fields from these RF emitters without the user's awareness. If abnormal performance of the Clearo is observed and the RF emitters cannot be identified and removed, the Clearo may need to be reoriented or relocated.
  - The Clearo, any accessories and all replaced parts must be disposed of in accordance with the local environmental regulations regarding the disposal of used equipment and waste.
  - The performance of the Clearo and treatment of the patient may deteriorate if the operational conditions are not fulfilled, see 9.4 *Environmental Operating Conditions*, page 55.



### 3 Product Description

#### 3.1 Main Components

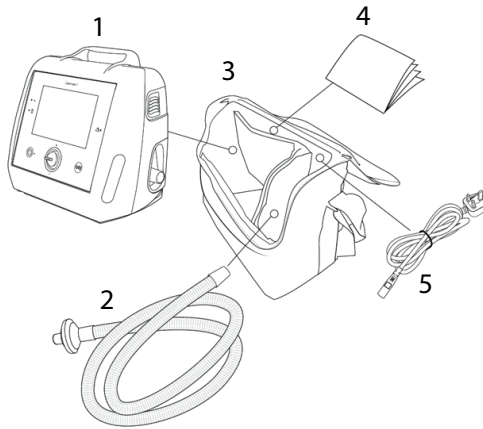



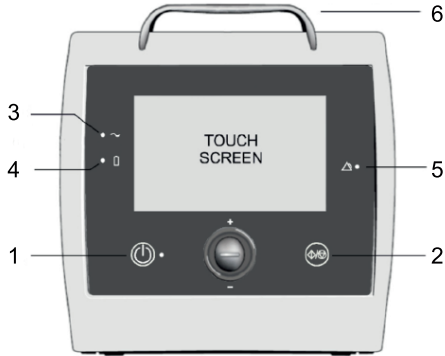

No.	Description	Product Code
1	Clearo Device	232000
2	Patient MI-E Circuit	010622
3	Clearo Carry Bag	009067
4	User Manual	010076
5	AC Mains Power Cord	010080 See 10 <i>Accessories</i> , page 61 for national specific power cords.

*The items delivered with the Clearo may differ depending on region and accessories ordered. For more information about accessories, please see 10 *Accessories*, page 61.*

### 3.2 Front Panel



No.	Symbol	Description	LED
1		Standby ON/OFF	Green
2		Start/Stop Treatment	(None)
3		AC Power Source	Green
4		Internal Battery	Green
5		Alarm	Amber
6	—	Carry handle	(None)

### 3.3 Side Panels

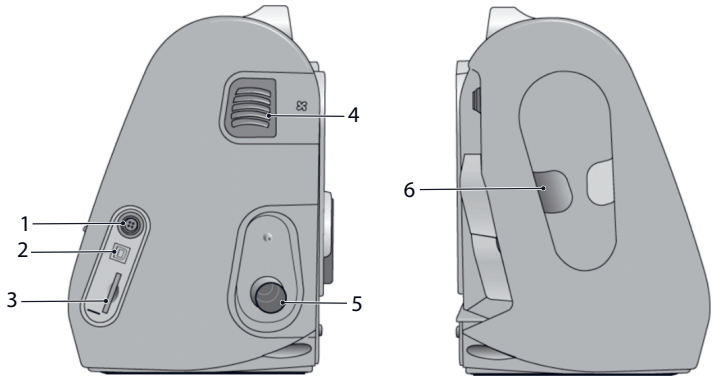

No.	Description
1	SpO <sub>2</sub> Connection
2	USB Connection. Restricted to use by Breas Medical Service only.
3	SD memory card slot. Restricted to be used to save patient compliance data to a memory card, only.
4	Cooling air outlet
5	Patient air outlet
6	Hand remote dock (optional)





### 3.4 Back Panel



















No.	Description
1	Serial number and identification code
2	Air inlet, with filter
3	Negative air outlet
4	Connector for hand remote
5	AC power (Mains) inlet
6	Internal battery cover

### 3.5 Equipment Designations and Safety Labels

Below is a table of symbols that are used on the device:

Symbol	Description
	USB (Universal Serial Bus)
	Memory Card
<b>SpO<sub>2</sub></b>	SpO <sub>2</sub> (Peripheral Capillary Oxygen Saturation)
	Attention: Read the intended use in the manual. Read the Safety chapter in the manual.
	Class II Equipment; Double Insulation
	Body Floating (IEC 60601-1 Type BF, Isolated Applied Part)

Symbol	Description
	Read Disposal section
	Read User Instructions before use
	Manufacturer
	Date of Manufacture: YYYY-MM-DD
	Country of manufacture
	AC Power input
No SpO <sub>2</sub> Alarm	No SpO <sub>2</sub> alarms fitted to the device
IP22	Ingress protection rating against solids and liquids
	Meets all requirements for CE marking according to applicable European health, safety and environmental protection legislation
	Meets all requirements for UKCA marking according to applicable United Kingdom health, safety and environmental protection legislation
<b>Rx Only</b>	Caution: U.S. Federal law restricts this device to sale by or on the order of a licensed healthcare practitioner. (Symbol only applicable in U.S.)
	Product catalogue number
	Serial number
	This product is a medical device
	EU authorized representative
	General warning symbol

Symbol	Description
	Indicates the maximum temperature limits at which the product shall be stored, transported or used
	Product shall be kept away from rain and in dry conditions.
 <b>Li-ion</b>	The product or its material is part of a recovery or recycling process

## 4 Preparing the Clearo for Use



### WARNING!

Ensure you have read 2 *Safety information*, page 10 before setting the Clearo up for use.

### 4.1 Checking the Device before Use

When using the Clearo for the first time, follow the instructions below:

- Read 2 *Safety information*, page 10 before setting up the Clearo.
- Check that all main components and ordered accessories have been delivered with the device. (Refer to the packing note or the invoice, if available.)
- Ensure that the equipment is in good condition.
- If stored more than one month, connect the Clearo to the power supply to recharge the internal battery (if fitted with a battery). See 5.14 *Using Batteries*, page 32 for further instructions.
- Check that both white and grey air filters are installed within the air inlet, see 7.2 *Air Inlet Filters Maintenance*, page 49.

### 4.2 Placing the Clearo Ready for Use



### WARNING!

Always ensure AC power (mains) plug is accessible to easily disconnect.

- Read the chapter 9.4 *Environmental Operating Conditions*, page 55 to make sure all conditions are met and considered.
- Place the Clearo on a solid, stable, flat surface.
- The Clearo should be placed lower than the patient in order to prevent the device from falling on the patient.
- Make sure that nothing can block the patient air inlets.
- Do not place the Clearo on a soft, or dusty surface, as this could make the device unstable, or result in dusty air to be drawn into the device.
- Never cover the device.

### 4.3 Connecting to AC Power (Mains)

- Read 2.2 *Electrical Safety*, page 12 carefully to make sure all conditions are considered and met.
- Ensure nothing is blocking the AC power cable that may cause difficulty disconnecting the mains power.
- AC Mains cable must be fitted with a 10 (A) amp fuse.
- Always use the correct AC mains cable.

## 4.4 Inspecting the Clearo before Use

Inspection of device before use

- Check that there is no visible damage.
- Check that the surface is clean.

Inspection of Cables

- Check that all cables are recommended by Breas Medical AB. See 10 *Accessories*, page 61
- Check that the cables are undamaged.
- Check that the cables are properly connected.

Inspection of Placement

- The Clearo shall be placed on solid flat surface below the patient level. (See 4.2 *Placing the Clearo Ready for Use*, page 20.)
- Make sure that nothing can block the air inlets on rear and side of the device.

## 5 How to Use the Clearo



### WARNING!

The Clearo should only be used by trained carers/users of the device. Using the device without training may cause serious harm or injury to the patient.

If you have not been trained on the device, contact the referring clinician or home care provider.

You must only use the device as instructed by the referring physician. Failure to do so may cause harm to the patient.

### 5.1 Connecting the Patient Circuit

Always inspect the circuit prior to use. Connect the circuit to the device by pushing the cuff onto the patient air outlet.

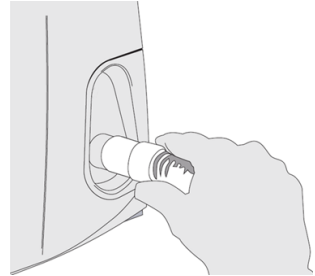

### WARNING!

Fit a bacterial filter close to patient mask, to minimize the risk of contamination of the Clearo device and circuit.

### 5.2 Circuits

Name	Part number
MI-E Circuit (Single patient, multiple use)	010622
	010466 (10 pcs)

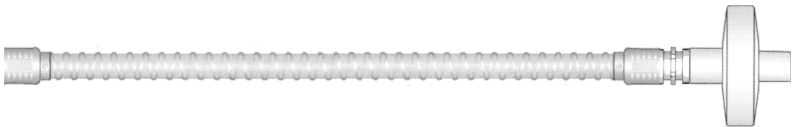

### 5.3 Turning the Device On/Off

To turn the device on, plug the device into the mains (AC), or use the internal battery as required, and then press the 'standby' button (see 3.2 *Front Panel*, page 15.)

















The device will be in standby mode. When the device has been switched on, a message appears asking the user to “ensure bacterial filter is fitted before use”. This message must be acknowledged before continuing with any treatment.

To turn off (shutdown), press the ‘standby’ button, a shutdown icon will appear in the centre of the LCD touch screen. Press the power icon on the touchscreen to shut down the device. Alternatively press the ‘standby’ button for twenty seconds.

## 5.4 On-Screen Symbols

The Clearo screen can contain the symbols and settings below. A summary of their meaning is included in the below table.

Symbol	Description
	Help button – where available, can be pressed to gain information or help.
	Hide button – to hide the current screen
	Confirm an option or selection ( <u>not</u> used for dynamic settings)
	Delete – Delete the current selected value
	Plus – Increase a value or parameter
	Minus – Decrease a value or parameter
	Locked – Indicates the device is locked
	Unlocked – Indicates the device is unlocked
	An alarm condition has been acknowledged
	Indicates the status of the Internal Battery (if fitted)
	Brightness level of the screen
	Sound level of the device audio
	Synchrony Beep® – Audible tone to signal the start of the Exsufflation phase
	Recruitment Breaths

## 5.5 General Functionality and Display

The **Clearo** is a **touch screen device**, and all settings and parameters are changed on-screen. Treatment is controlled only using the 'hard' buttons on the device (i.e. start/stop, manual switch, hand controller).

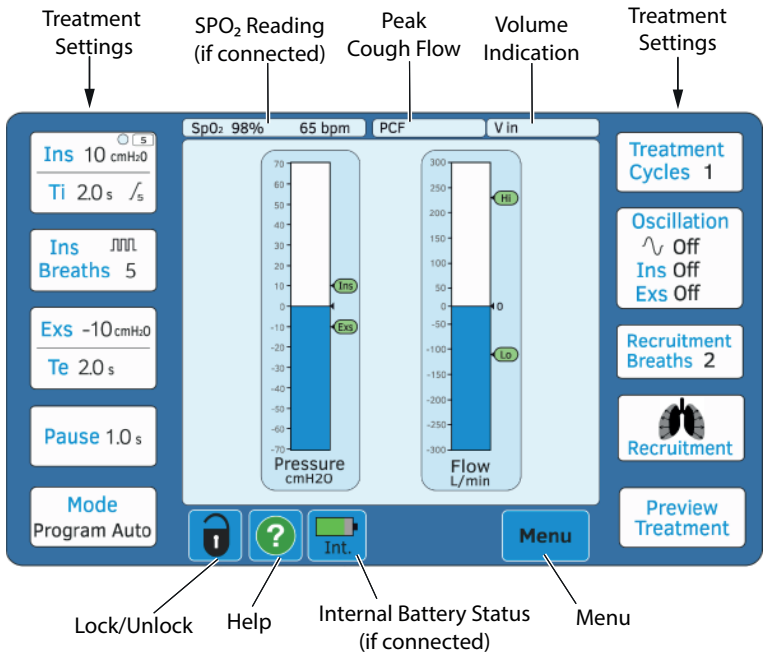

The treatment settings INS and EXS are displayed on the bar-graph, to indicate the Insufflation and Exsufflation pressure, respectively, set by the user.

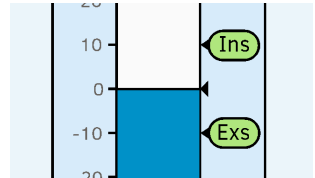

The Clearo uses a **Resistive Touchscreen** enabling operation with users wearing gloves as part of their personal protective equipment (PPE). Resistive touch screen may not feel as responsive to users familiar with touchscreens and may require slightly more force to use than common devices such as smart phones.

## Peak Cough Flow

Peak Cough Flow (PCF) is indicated by a marker on the Flow Bar as a live reading. It is the assisted expiratory flow during exsufflation of the device with or without the patient coughing. The marker will be reset following each Exsufflation (cough), and a new PCF marker will be displayed.

### CAUTION!

The figures displayed should only be used to assess effectiveness of treatment by reviewing comparisons on the device. If required, peak expiratory flow levels should be obtained using equipment compliant with EN ISO 23747:2015 Anesthetic and respiratory equipment.



## The Pin Symbol

The pin symbol indicates that the settings window must be manually closed and will not timeout after 10 seconds.

The pin can be activated by pressing the desired setting twice to make the setting window stay visible on screen, even during treatment for live adjustments to the treatment settings.



## 5.6

### The Main Menu

The Menu is accessed using the 'Menu' button at the bottom of the screen.

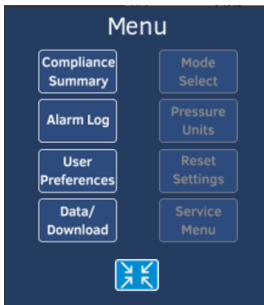

*The Menu. The dimmed items are not available in locked mode.*

## Compliance Summary

1 On the **Menu**, select **Compliance Summary** and then select the number of days to view.

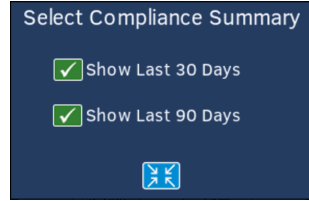

2 The compliance data is now displayed.

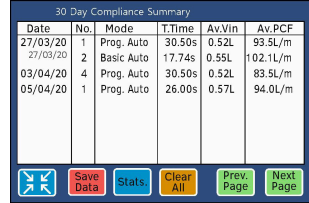

Date	No.	Mode	T.Time	Av.Vin	Av.PCF
27/03/20	1	Prog. Auto	30.50s	0.52L	93.5L/m
27/03/20	2	Basic Auto	17.74s	0.55L	102.1L/m
03/04/20	4	Prog. Auto	30.50s	0.52L	83.5L/m
05/04/20	1	Prog. Auto	26.00s	0.57L	94.0L/m

## Alarm Log

1 On the **Menu**, select **Alarm Log** and then select the number of days to view.

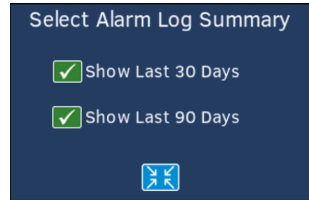

2 The alarm log is now displayed.

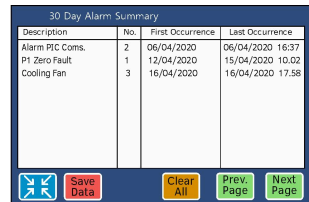

Description	No.	First Occurrence	Last Occurrence
Alarm PIC Coms.	2	06/04/2020	06/04/2020 16:37
P1 Zero Fault	1	12/04/2020	15/04/2020 10.02
Cooling Fan	3	16/04/2020	16/04/2020 17.58

## User Preferences

On the **Menu**, select **User Preferences**. The user preferences window is now displayed.

Some limited user settings are available in the locked 'user' mode.

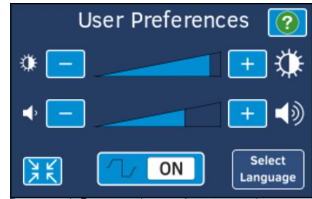

### Screen Brightness

Adjust the brightness of the screen using the plus and minus buttons, to increase or decrease the brightness.



### Device Volume

Adjust the volume of the audible notification tones using the plus and minus buttons. (Alarm sound level is not affected by this setting)



### Synchrony Beep

The synchrony beep is intended to assist the patient and therapist/carer to synchronise their treatment, and hence improve effectiveness of the therapy. This may be to help the patient cough in synchrony with the negative pressure delivery, or for the therapist/carer to time delivery of any appropriate manual techniques.

The synchrony beep can be de-activated/activated as required by pressing the synchrony button to toggle synchrony beep on and off.



### Select Language

Select the language for the user interface.

## Mode Select Options

On the **Menu**, select **Mode Select**. The Mode Select Options screen is now displayed. Here you can select each mode that is available to the user from the Mode Select screen.

The example screen (above) shows all modes available, except for Profiles 3 and 4, because no MI-E treatments or Treat Repeats have been saved to these profiles. See for more information on 'Treat Repeat and Saved Profiles.

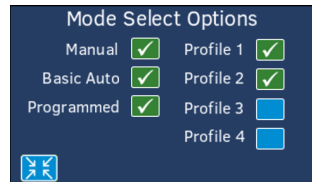

## Pressure Units

The Pressure Units setting changes the measurement units for Pressure throughout the device, between cmH<sub>2</sub>O and hPa.

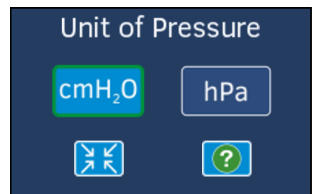

## Reset Mode Settings

The Reset Settings function allows the user to clear all user settings to defaults in the current mode, or all modes.

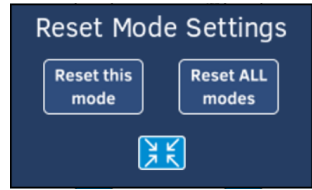

## Service Menu



The service menu is accessed by a service code. Refer to Service Manual for Service Menu information.

## 5.7 Treatment Settings

### 5.7.1 Selecting a Mode

The modes available may be restricted to the ones selected in the *Mode Select Options* screen, see *Mode Select Options*, page 27.

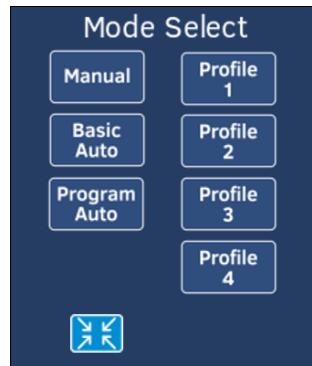

*Mode select screen, with all modes available.*

## 5.8 Profiles

A profile can be used to save either: a prescription within an MI-E mode, or a valid manual treatment that has been recorded and saved using TreatRepeat.

Unless the clinician has restricted access to specific modes, you can access any mode or saved profile by pressing the Mode button. See *Mode Select Options*, page 27 for restricting or enabling specific modes.

### 5.8.1 Loading a Treatment Profile

Only profiles with a stored treatment/prescription and that has been enabled in the Mode Select Options screen can be loaded.

1 Press the **Mode** button to open the Mode Select screen.



2 Press **Load Profile** and then select the profile to load.

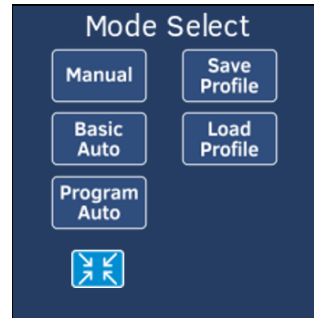

## 5.9 Starting and Stopping Treatment



### NOTE

If required, you can terminate a treatment while it is being delivered.

- In manual mode: Stop the treatment by releasing the front switch or the switch on the hand controller, whichever has been used for starting the treatment.
- In auto or programmed modes, press the **Start/Stop Treatment** button.

### 5.9.1 Starting a Manual Mode Treatment

1 On either of front panel or the hand control, use the treatment switch to start the treatment.

Push the switch up for insufflations and down for exsufflations. Release the switch for a pause.

2 To end the treatment, release the switch.



## 5.9.2 Starting an Automatic Treatment

To start a treatment saved to a profile, or defined in the Mode settings:

- 1 On the **Mode select** screen, select the treatment to start.
- 2 If a trigger is defined in the treatment, the treatment starts when the patient triggers the cycle by an inhalation effort.
- 3 If a trigger is not defined in the treatment: On either of front panel or the hand control, press the Treatment Start/Stop button.
- 4 To stop a running treatment, press the Start/Stop button.

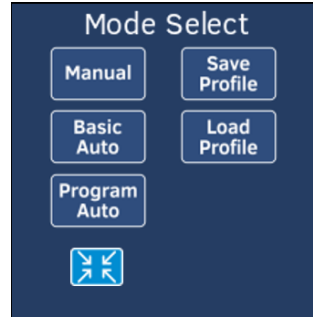

## 5.10 Recruitment Breaths

Recruitment Breaths can be used before or after the treatment, to promote re-recruitment and help the patient recover following treatment. Recruitment Breaths are only available in the Basic Auto and Program Auto modes. Use only as advised by the referring physician. Recruitment Breaths are delivered at the same insufflation pressure set for the treatment.

### **WARNING!**



Always ensure the patient has cleared any large airway secretions through expectorating, or suction, prior to starting the Recruitment Breaths, to prevent the secretions being pushed distally.

## Activating the Recruitment Breaths

For using recruitment breaths, the number of breaths must have been defined by the physician during the set up.

- 1 Press the **Recruitment** button on the screen.
- 2 On the front panel or the hand control, press the Treatment Start/Stop button.

To stop the treatment before the programmed number of breaths are delivered, press the Start/Stop button again.

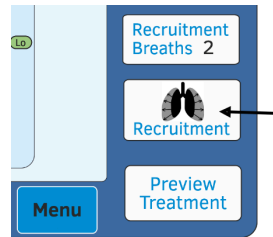

## 5.11 View Treatment Waveforms

### Preview Treatment

When the Clearo is in standby and in any of the automatic MI-E modes, including a saved TreatRepeat program, the programmed treatment waveforms can be previewed by pressing the Preview Treatment button.

In the preview screen, Pressing the arrow buttons moves the view forward or backward through the treatment program. In Manual Mode it is only possible to View Treatment that is being delivered by the manual switches.



### View the Active Treatment

When the Clearo is delivering treatment in an automatic Mi-E mode, you can press the Preview Treatment button to see a visual representation of the programmed treatment. A vertical line follows the treatment as it is being delivered. This may help patients to synchronise with the Clearo when using it by allowing them to keep track of the treatment program.

In the Manual Mode, users can press the View Treatment button to see live feedback waveforms of the pressure being delivered.

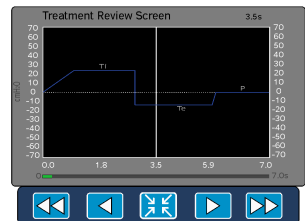

## 5.12 Use with the SpO<sub>2</sub> Sensor

The SpO<sub>2</sub> displays the patient's oxygen saturation, if measured with SpO<sub>2</sub> module accessory. When using the Clearo with the SpO<sub>2</sub> sensor accessory, it is calibrated to display functional oxygen saturation.

To use the SpO<sub>2</sub> sensor with the Clearo, it must be connected to the side of the device, see 3.3 *Side Panels*, page 16.



### **WARNING!**

Warning: Prolonged use of the SpO<sub>2</sub> sensor can cause contact injuries to the patient's skin.

The SpO<sub>2</sub> reading will be displayed live on the main screen of the Clearo.

The user will be notified with an alarm if the SpO<sub>2</sub> sensor becomes disconnected. If the data collected from the sensor is corrupted or unreadable, the SpO<sub>2</sub> reading will display a “?” next to the reading.

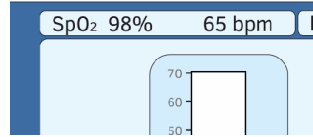

Environmental factors may influence the function or accuracy of the pulse oximeter such as ambient light, physical movement, diagnostic testing, low perfusion, electromagnetic interference, dysfunctional haemoglobin, presence of certain dyes and inappropriate positioning of the pulse oximeter probe.

A functional tester cannot be used to assess the Accuracy of a Pulse Oximeter Probe or a Pulse Oximeter.

## **5.13 Accessing User Data**

The clinician who is managing the patient's care has access to detailed data about the therapy and the amount of time the device is used each day.

Some data is also available for you to review in the locked, home mode of the device.

## **5.14 Using Batteries**



### **WARNING!**

Only use the batteries described in the Accessories chapter, see 10 *Accessories*, page 61.

Use of any other battery may lead to improper or unsafe operation.

The internal battery is not designed to be user replaceable. Please contact technical support if a replacement is required.

The Clearo may be powered by an internal battery. The Clearo monitors the condition of the battery (if fitted) and automatically charges it as required when connected to the AC mains, and not in use.

### **Battery State of Charge**

The Internal battery icon will be visible at the bottom of the main screen only if a battery is fitted. The icon briefly displays the state of charge and can be pressed to show a more detailed view of the battery status.





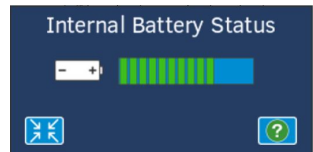

The state of charge is displayed as a bar graph and will change colour depending on the charge level.

A yellow charge level means the battery level is below 50%, and a red charge level means the battery is very low.



## Battery Symbols

The battery symbol will change depending on the state of the battery.

Symbol	Description
	Internal battery connected.
	Battery charging.
	Battery not connected.
	Battery fault. Contact your service provider.
	This battery symbol will be shown in the battery status screen if the battery requires a replacement. An alarm will also be shown.
	Battery under/over temperature. <10°C or >45°C

The battery LEDs on the front of the Clearo will be solid if the battery is in use, and flash if the battery is charging.

## Internal Battery

If available, an internal battery can be fitted inside the Clearo, see 3.4 *Back Panel*, page 17. The battery pack is not designed to be installed or replaced by the user. If you experience improper function or replacement is required, contact your homecare provider, or Breas.

An internal battery will run for: >30 minutes in MI-E modes (based on settings of +40/-45 cmH<sub>2</sub>O, and T<sub>i</sub>, T<sub>e</sub>, and Pause times of 2 seconds). The capacity of lithium-ion batteries degrades over time and use, therefore older batteries and/or those that have been used extensively may not deliver the same running times as stated. Users that require battery back-up should regularly monitor the run-time they are able to achieve and replace the battery when necessary.

## Power Source Priority

1. AC Mains
2. Internal Battery (if fitted)

AC mains is the preferred power source. If the mains power supply is removed or fails, then Clearo will switch to the internal battery (if fitted). Switching to battery power is indicated by an on-screen message, and the power source is indicated by an LED.

## Charging the Batteries

Clearo monitors the internal battery and charges it automatically when the AC mains is connected.

The Clearo will not charge the battery when treatment is being performed.

## Storing Batteries

If the Internal battery is to be stored for a period of longer than 1 month it should be initiated at between 15-50% charge and stored at a temperature between +5 to + 30°C. This will ensure the battery retains maximum capacity. A battery that is not used will slowly discharge; this rate of discharge will increase when stored at higher temperatures.

## 5.15 Using the Hand Control

The hand control is an optional accessory for the Clearo which allows users to deliver manually insufflations and exsufflations using the switch. Also, it allows users to start and stop automatic treatment prescriptions.

The hand control must be connected to the Clearo to use it. It is connected at the back of the device at the point labelled with the hand control icon, see section 3.4 *Back Panel*, page 17.

1. Manual switch used to deliver insufflations and or exsufflations.

To deliver insufflations using the hand control, press the manual switch to the up position. To deliver exsufflations using the hand control press the manual switch to the down position. Insufflations and exsufflations are delivered if the switch position is held up to a maximum of five seconds.

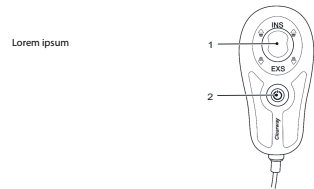

2. Standby button used to change the state of the Clearo between stand-by and active treatment (start/stop automatic treatment).

To deliver automatic treatment using the hand control press the standby button. To stop an automatic treatment, press either the standby button or manual switch.

## 5.16 Transferring Data



### NOTE

Do not connect an SD card to the Clearo during treatment. Downloading of data is prohibited by software during treatment.

### Compliance Data

Patient compliance data may be downloaded to a PC via an SD card, by selecting 'Compliance Summary' from the Main Menu.

The Clearo must be unlocked for downloading compliance data.

- 1 From the **Menu**, select **Compliance summary**.
- 2 Select the number of days data you want to view and press the **Save Data** button.
- 3 Insert an SD card and press the tick icon.

A green tick in the SD card Icon is displayed if transfer is successful.



## Settings Data

An SD card can be used for saving and loading settings from the Clearo. This is useful when replacing a device, or for creating backups.

**1** On the **Menu**, select **Data/Download**.

**2** Select whether to **Save** or **Load** data.

**3** Insert an SD card, and press the tick button.

A green tick represents a successful data transfer. If the data transfer was unsuccessful, a red cross will be displayed instead.

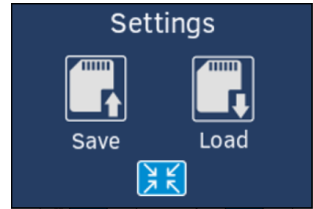

# 6 Alarms

## 6.1 Alarm Function

The alarm function of the Clearo consists of a yellow LED on the front panel, an audible alarm and a message box on the front LCD screen. See 3.2 *Front Panel*, page 15 for an overview of the front panel.

The visual alarm indicators are visible within a distance of 4 metres and to within an angle of 30° facing the front panel. The operator must be within the audible range to receive the audible alarm.

## 6.2 Alarm Indication

### Medium Priority alarm

LED – Yellow colour, one flash every 2 seconds

Audible - 3 signals repeated after a 3 second pause

Message – Yellow box on screen with information in black writing

### Low Priority alarm

LED – Solid yellow

Audible – 2 signals

Message – Yellow box on screen with information in black writing

### Message

LED – none

Audible – none

Message – Blue box on screen with description of the message.



The power fail alarm will only be indicated by a yellow flashing LED and constant audible alarm

## 6.3 Alarm Reset

An alarm condition will be automatically reset when the cause of the alarm has been corrected or the alarm condition no longer exists.



### WARNING!

If an alarm cannot be corrected, stop using the Clearo and request technical support

When an alarm has been acknowledged on screen, the alarm message will disappear unless the fault is reoccurring or still exists. If the fault still exists after acknowledgment, the alarm symbol will remain on screen and enables the user to view the current list of live alarms.

## 6.4 Alarms and Messages Descriptions

### 6.4.1 High Pressure Alarm

Item	Description
Definition	120% of set pressure is detected for > 2 seconds
Priority	Medium
Modes	All
Possible cause	Cough during inspiration
Clearo action	Treatment stops. The on-screen message must be acknowledged. Treatment cannot be started until message has been acknowledged
On Screen Message	“High Pressure Alarm! Treatment has stopped! - Restart the Clearo - Contact your supplier if fault persists”

### 6.4.2 Power Source Changed Alarm

Item	Description
Definition	Power source changed
Priority	Low
Modes	All
Possible cause	Power source changed
Clearo action	Treatment continues
On Screen Message	Either of: <ul style="list-style-type: none"><li>• Power source changed -now using internal battery</li><li>• Power source changed -now using AC mains</li></ul>

#### NOTE

A Machine Fault can be caused by several different faults with the device. All Machine Faults require the user to restart the device, and to contact the supplier if the fault persists



### 6.4.3 Power Fail Alarm

Item	Description
Definition	All power sources have been lost.
Priority	Medium
Modes	All
Possible cause	All power sources have been lost. Mains not connected, and batteries discharged
Clearo action	Treatment not possible. Constant audio alarm and flashing LED
On Screen Message	N/A

#### 6.4.4 Pressure Measurement Fault Alarm

Item	Description
Definition	Fault detected in pressure measurement
Priority	Medium
Modes	All
Possible cause	Internal pressure measurement fault
Clearo action	Treatment stops. The on-screen message must be acknowledged. Treatment cannot be started until message has been acknowledged
On Screen Message	“Pressure Zero Fault! Treatment has stopped! - Restart the Clearo - Contact your supplier if fault persists”

#### 6.4.5 Pressure Sensor Fault Alarm

Item	Description
Definition	Mismatch between pressure sensor 1 and 2
Priority	Medium
Modes	All
Possible cause	Internal Pressure measurement fault
Clearo action	Treatment stops. The on-screen message must be acknowledged. Treatment cannot be started until message has been acknowledged
On Screen Message	“Pressure sensor fault! P1 and P2 Difference - Treatment has stopped! - Restart the Clearo - Contact your supplier if fault persists”

#### 6.4.6 Battery Exhausted Alarm

Item	Description
Definition	Internal battery state of charge < 40%
Priority	Medium
Modes	All
Possible cause	Internal battery state of charge < 40%
Clearo action	Treatment continues New treatment session cannot be started, but manual switch remains active. Message must be acknowledged to clear
On Screen Message	Internal Battery Exhausted - Device Shutting Down - Connect alternative power source

### 6.4.7 SpO<sub>2</sub> Sensor Disconnected Alarm

Item	Description
Definition	SpO <sub>2</sub> Sensor Disconnected
Priority	Low
Modes	All
Possible cause	SpO <sub>2</sub> sensor has been disconnected either at in-line connector or at Clearo. SpO <sub>2</sub> sensor has failed.
Clearo action	Treatment continues Message must be acknowledged to clear.
On Screen Message	“SpO <sub>2</sub> sensor disconnection! Patient SpO <sub>2</sub> sensor has been disconnected”

### 6.4.8 Low Battery Power Alarm

Item	Description
Definition	Internal battery state of charge < 50%
Priority	Low
Modes	All
Possible cause	Internal battery state of charge < 50%
Clearo action	Treatment continues Message must be acknowledged to clear
On Screen Message	Low Battery Power - Connect Alternative power source

### 6.4.9 Treatment too Long Message

Item	Description
Definition	Treatment performed is too long to be saved in TreatRepeat
Priority	Message
Modes	Manual
Possible cause	The performed manual treatment is too long to be saved as a valid treatment in TreatRepeat
Clearo action	Treatment is not saved.
On Screen Message	“Treatment too long! Try recording a shorter treatment”

#### 6.4.10 MI-E Mode Selected Message

Item	Description
Definition	MI-E mode selected
Priority	Message
Modes	Manual, Basic Auto, Program Auto, TreatRepeat
Possible cause	MI-E mode selected
Clearo action	Message must be acknowledged to clear.
On Screen Message	Ensure correct circuit is used Ensure bacterial filter is fitted before use!

#### 6.4.11 Treatment has Finished Message

Item	Description
Definition	Selected treatment has finished.
Priority	Message
Modes	Basic Auto, Program Auto
On Screen Message	“Treatment has Finished!”

#### 6.4.12 SPO<sub>2</sub> Connected Message

Item	Description
Definition	Notification that an SPO <sub>2</sub> sensor is connected to the Clearo.
Priority	Message
Modes	All
On Screen Message	“SpO <sub>2</sub> SENSOR CONNECTED There are no SpO <sub>2</sub> Alarms!”

#### 6.4.13 Treatment Not Saved Message

Item	Description
Definition	Attempt to save Basic Auto treatment to profile 1-4 when Pause is set to <0.5 seconds
Priority	Message
Modes	Manual, Basic Auto, Program Auto, Treatrepeat
On Screen Message	“TREATMENT NOT SAVED! No valid treatment recorded”

## 6.5 Machine Fault Message Descriptions

### 6.5.1 Internal Battery Health Bad

Item	Description
Definition	Internal Battery due replacement soon
Priority	Message
Modes	All
Possible cause	Internal battery state of health below 70%
Clearo action	Treatment continues.
On Screen Message	“Internal battery health bad”

### 6.5.2 Over Temperature

Item	Description
Definition	Internal temperature is > 60° C.
Priority	Medium
Modes	All
Possible cause	Ambient temperature is high. Device is positioned in sunlight or close to a heat source. Air inlet filters are blocked (e.g. placed on a bed or soft surface)
Clearo action	Treatment continues.
On Screen Message	“Over Temperature! Switch device OFF. Leave for 30 minutes”

### 6.5.3 Low Alarm Battery Fault

Item	Description
Definition	Internal alarm battery must be replaced.
Priority	Medium
Modes	All
Possible cause	Alarm battery voltage is low. Connect Clearo to mains to charge battery. If message persists, contact technical support for battery replacement.
Clearo action	Treatment is still possible. Power fail alarm may be low volume or not functioning. (Contact technical support for battery replacement)
On Screen Message	“Low Alarm battery! - Connect Mains power and leave to charge - Contact your supplier if fault persists”

#### 6.5.4 Mains Power Fault

Item	Description
Definition	Machine fault
Priority	Medium
Modes	All
Possible cause	The internal power supply cannot deliver the correct voltage. Check the mains power outlet, restart the device. If the alarm persists, stop using the device and contact your supplier.
Clearo action	Treatment will stop.
On Screen Message	Mains power fault

#### 6.5.5 Blower Driver Fault

Item	Description
Definition	Machine fault
Priority	Medium
Modes	All
Possible cause	IC fault state Restart the device. If the alarm persists, stop using the device and contact your supplier.
Clearo action	Treatment will stop.
On Screen Message	Blower drive fault

#### 6.5.6 Valve Zero Fault

Item	Description
Definition	Machine fault
Priority	Medium
Modes	All
Possible cause	Valve zero calibration not performed. Restart the device. If the alarm persists, stop using the device and contact your supplier.
Clearo action	Treatment will stop.
On Screen Message	Valve zero fault

### 6.5.7 Valve Drive Fault

Item	Description
Definition	Machine fault
Priority	Medium
Modes	All
Possible cause	Valve drive error Restart the device. If the alarm persists, stop using the device and contact your supplier.
Clearo action	Treatment will stop.
On Screen Message	Valve drive fault

### 6.5.8 Alarm PIC Communications Fault

Item	Description
Definition	Machine fault
Priority	Medium
Modes	All
Possible cause	I2C comms fault between Alarm PIC and Main PIC Restart the device. If the alarm persists, stop using the device and contact your supplier.
Clearo action	Treatment will stop.
On Screen Message	Alarm PIC communications fault

### 6.5.9 Internal Module Communications Fault

Item	Description
Definition	Machine fault
Priority	Medium
Modes	All
Possible cause	Comms fault between Main PIC and Power PIC Restart the device. If the alarm persists, stop using the device and contact your supplier.
Clearo action	Treatment will stop.
On Screen Message	Internal module communications fault

### 6.5.10 Blower Fault

Item	Description
Definition	Machine fault
Priority	Medium
Modes	All
Possible cause	Blower not connected / not working (zero current) Restart the device. If the alarm persists, stop using the device and contact your supplier.
Clearo action	Treatment will stop.
On Screen Message	Blower fault

### 6.5.11 Blower Speed Fault

Item	Description
Definition	Machine fault
Priority	Medium
Modes	All
Possible cause	Blower speed is below 100% Restart the device. If the alarm persists, stop using the device and contact your supplier.
Clearo action	Treatment will stop.
On Screen Message	Blower speed fault

### 6.5.12 Valve Position Fault

Item	Description
Definition	Machine fault
Priority	Medium
Modes	All
Possible cause	Valve not connected / not working (zero current) Restart the device. If the alarm persists, stop using the device and contact your supplier.
Clearo action	Treatment will stop.
On Screen Message	Valve position fault

### 6.5.13 Valve Current Fault

Item	Description
Definition	Machine fault
Priority	Medium
Modes	All
Possible cause	Valve not working (high current) Restart the device. If the alarm persists, stop using the device and contact your supplier.
Clearo action	Treatment will stop.
On Screen Message	Valve current fault

### 6.5.14 Blower Current Fault and/or Blower Speed Fault

Item	Description
Definition	Machine fault
Priority	Medium
Modes	All
Possible cause	Blower is prevented from rotating while blower current is > 4.5A for >1.5s. Restart the device. If the alarm persists, stop using the device and contact your supplier.
Clearo action	Treatment will stop.
On Screen Message	Blower current fault and/or blower speed fault

### 6.5.15 Blower Speed Fault

Item	Description
Definition	Machine fault
Priority	Medium
Modes	All
Possible cause	Blower speed less than set speed. Loss of one or more field connections. Restart the device. If the alarm persists, stop using the device and contact your supplier.
Clearo action	Treatment will stop.
On Screen Message	Blower speed fault

### 6.5.16 Blower Control Fault and/or Blower Fault

Item	Description
Definition	Machine fault
Priority	Medium
Modes	All
Possible cause	Loss of one or more position signals. Restart the device. If the alarm persists, stop using the device and contact your supplier.
Clearo action	Treatment will stop.
On Screen Message	Blower control fault and/or blower speed fault

### 6.5.17 Blower control Fault

Item	Description
Definition	Machine fault
Priority	Medium
Modes	All
Possible cause	Loss of blower sensor supply. Restart the device. If the alarm persists, stop using the device and contact your supplier.
Clearo action	Treatment will stop.
On Screen Message	Blower control fault

### 6.5.18 Valve Current Fault

Item	Description
Definition	Machine fault
Priority	Medium
Modes	All
Possible cause	Valve seized. Restart the device. If the alarm persists, stop using the device and contact your supplier.
Clearo action	Treatment will stop.
On Screen Message	Valve current fault

### 6.5.19 Valve Drive Fault

Item	Description
Definition	Machine fault
Priority	Medium
Modes	All
Possible cause	Valve drive open circuit. Restart the device. If the alarm persists, stop using the device and contact your supplier.
Clearo action	Treatment will stop.
On Screen Message	Valve drive fault

### 6.5.20 Valve Position Fault

Item	Description
Definition	Machine fault
Priority	Medium
Modes	All
Possible cause	Angle transducer + open circuit (positive) <0.3V Angle transducer - open circuit (negative) >4V Angle transducer output open circuit 0V Restart the device. If the alarm persists, stop using the device and contact your supplier.
Clearo action	Treatment will stop.
On Screen Message	Valve drive fault

### 6.5.21 Alarm Battery Fault

Item	Description
Definition	Machine fault
Priority	Medium
Modes	All
Possible cause	Alarm battery overvoltage (>4.4 V) Restart the device. If the alarm persists, stop using the device and contact your supplier.
Clearo action	Treatment continues.
On Screen Message	Alarm battery fault

## 7 Cleaning and Maintenance

### WARNING!

The Clearo should be cleaned and maintained in accordance with this manual.

- The Clearo should undergo maintenance, service, and control procedures, as well as any applicable upgrades, in accordance with the Breas Clearo Service Manual.
- The Clearo shall only be repaired or modified in accordance with the Breas, Clearo Service Manual, technical bulletins, and any special service instructions, by service technicians that have been certified to do so after completing Breas Clearo Technical Training.
- Do not under any circumstances attempt to service or repair the Clearo yourself. If you do so, the manufacturer will no longer be responsible for the performance and safety of the device. Furthermore, no guarantees will be valid.
- Do not attempt to autoclave the Clearo main unit.

DEVIATION FROM THESE SERVICE INSTRUCTIONS MAY LEAD TO RISK OF PERSONAL INJURY!



### Recommended Replacement Intervals

#### • Patient circuit and connector:

- Replace every 3 months (90 days.) The replacement intervals should be established by the responsible healthcare organization, based on the its infection control procedures and the instructions from the patient circuit's manufacturer.
- Replace the circuit if it becomes discolored, cracked or damaged.
- Multiple patient use of the Clearo: Replace the patient circuit and filter connector at change of patient.



The patient circuit should be maintained in accordance with the manufacturer's instructions, or by the responsible healthcare organization's instructions.

#### • Bacterial filter

- Replace after 24 hours usage. The responsible healthcare organization should determine the maximum duration of use based on accepted infection control procedures.
- Replace if visual contamination (e.g. secretions) is observed. Do not attempt to clean the bacterial filter.
- Multiple patient use of the Clearo: Replace the bacterial filter at change of patient.

### CAUTION!

All replaced parts must be disposed of in accordance with local environmental regulations regarding the disposal of used equipment and waste.



### NOTE

The cleaning and replacement procedures may be carried out by a lay operator in a homecare environment.



## 7.1 Cleaning the Clearo



### WARNING!

To avoid electrical shock, disconnect the mains supply to the Clearo before cleaning. Do not immerse the device into any fluids.



### CAUTION!

- Always be careful when cleaning to ensure that you do not damage any equipment.
- Fluid must not be allowed to enter the Clearo.
- Never apply any liquids directly on the Clearo by spraying, splashing, or pouring. Use a moistened lint-free cloth when cleaning.
- Do not use an excessive amount of liquid when cleaning the Clearo.
- Do not autoclave the Clearo.

### Cleaning the Exterior of the Clearo

Inspect the device, power cord and patient circuit for damage whilst cleaning. If there is any damage noticed, do not continue to use the device, and contact your care provider, hospital or referring clinician immediately.

- 1 Turn off the Clearo and disconnect the mains supply.
- 2 Remove the patient circuit.
- 3 Disconnect all electric cables.
- 4 Clean the outside of the Clearo using wipes containing ethanol 70%. Perform a visual inspection of the cleaned areas to ensure there are no visual contaminants. Repeat the cleaning if required.

For performing a surface disinfection of the Clearo, the contact time with the ethanol solution shall be at least one minute. See the disinfection agent's instructions for further instructions.

- 5 Clean optional accessories in accordance with their respective user instructions.
- 6 Allow all cleaned parts to air dry.
- 7 Visually inspect the Clearo and accessories that have been cleaned. If any part is not visually clean and dry, repeat the associated cleaning steps or safely dispose of it.
- 8 Reconnect the patient circuit, electric cables and accessories before putting the Clearo back into operation.

## 7.2 Air Inlet Filters Maintenance

The air inlet filters are located on the back of the device and accessed by simply removing the filter housing.

1. Cleanable coarse filter
2. Disposable fine filter
3. Filter housing

The filters should be inspected weekly, and changed if discoloured, or more frequently if advised by your referring clinician.

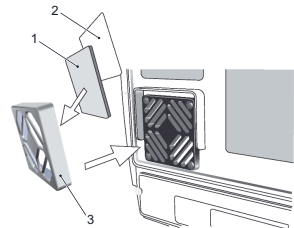



### CAUTION!

Be careful when fitting the filter housing to avoid pinching skin.

### Cleaning or Replacing the Coarse Filter (Grey)

Clean the coarse filter at least once a week and replace it at least once a year.

- 1 Pull out the filter housing.
- 2 Remove and separate the two filters.
- 3 Carefully vacuum the grey coarse filter to remove any build ups of dust. Check that the filter is visible clean and undamaged after cleaning. If not, replace the filter.
- 4 Insert the filters to the filter housing with the coarse filter before the fine filter and put back the filter housing to the Clearo.

### Cleaning or Replacing the Fine Filter (White)

Replace the white filter at least every 4th week, or more frequently when used in high pollution or pollen-rich environments.

### CAUTION!

Do not wash or reuse the disposable filter, this must always be replaced with a new filter.

- 1 Pull out the filter housing.
- 2 Remove and separate the two filters.
- 3 Replace the fine filter. Insert the filters to the filter housing with the coarse filter before the fine filter and put back the filter housing to the Clearo.

## 7.3 Change of Patient

### WARNING!

- If the Clearo is to be used by more than one patient, the patient circuit and the bacterial filter shall be replaced at change of patient.
- Disassembly by opening of the device main unit is not to be performed by unauthorized personnel as this should only be done by Breas Medical.
- Clearo is not suitable for sterilization.

- 1 Clean the Clearo as described in the section 7.1 *Cleaning the Clearo*, page 49.
- 2 Replace the air inlet filters according to 7.2 *Air Inlet Filters Maintenance*, page 49.
- 3 Use a new patient circuit and a new bacterial filter when the Clearo is used by a new patient.

## 7.4 Essential and Regular Maintenance Control

Essential maintenance is required for the Clearo after 5 years of service (please see Clearo Service Manual for further details). Breas advise annual checks to the Clearo to ensure electrical safety as well as flow and pressure calibration. The Service Manual outlines the test instructions for Electrical Device Safety Testing which should be carried out by trained service personnel.

### **CAUTION!**

Service and/or repair activities must not be carried out when a patient is connected to the Clearo or receiving treatment.



Do not use the device and contact your responsible care provider for an inspection of the device in the event of:

- Unexpected patient symptoms during treatment.
- Unexpected or sudden pressure, performance, or sound changes during operation.
- Suspected damage to the device, including the occurrence of machine fault / failure alarms.

Suspected damage to the internal battery, including evidence of battery cell leakage.

## **7.5 Service and Repair**

The service and repair of the Clearo must only be carried out by service personnel certified by Breas, in accordance with the Breas service instructions. Service inspections must always be carried out following any repairs to the device.



Authorised service workshops can order the Clearo Service manual that contains the technical documentation required for the maintenance and service of the Clearo.

## **7.6 Storage**

Store the Clearo device in a dark room, where the temperature range is within -20°C to +60°C (-4°F to +140°F). For instructions on how to charge the batteries after long time storage, see 5.14 *Using Batteries*, page 32.

### **CAUTION!**



- The Clearo must not be stored in a warm place, such as direct sunlight, close to a radiator or in a vehicle in sunlight.
- If stored in a cold environment, let the Clearo adapt to room temperature for at least 1 hour before using the device.

## **7.7 Transport**

The Clearo is a portable-operable device, and can be used during general transport by car, boat, or train. During transport it is advised to use the Clearo carry bag when not in use.

### **CAUTION!**



Do not power the device from a vehicle. Only use the internal battery supplied by Breas during transport (option).

## 7.8 Disposal

The Clearo, any accessories and all replaced parts must be disposed of and recycled in accordance with the local environmental regulations regarding the disposal of used equipment and waste.



### **CAUTION!**

Batteries used with the Clearo shall be recycled in accordance with the local environmental regulations.

## 8 FAQs and Troubleshooting

### 8.1 FAQs

#### 1. Can I travel with my device?

You should always notify your prescribing clinician if you intend to travel.

If you are traveling to a country with different voltage to the one you are currently using, you may require a different power cord or an international plug adaptor to ensure your power cord is compatible with the power outlets of the country to which you are traveling.

If you are planning to fly, or go on a cruise, you should always contact the company prior to travel. Documents can be downloaded from [www.breas.com](http://www.breas.com)

See 7.7 *Transport*, page 51 for further transport information.

#### 2. What is the service life of the Clearo?

The service life of the Clearo is 7 years if it is continuously regularly serviced and maintained.

All other Breas parts and accessories included or used with the Clearo have a 7-year service life. Disposable parts such as circuits and masks have a separate shelf life, and will be clearly labelled on the packaging of the disposables. Please refer to the packaging for shelf life.

#### 3. Does the Clearo have any SpO<sub>2</sub> alarms?

There is an SpO<sub>2</sub> sensor disconnection alarm. However, there are no alarms for low SpO<sub>2</sub> or any other SpO<sub>2</sub> related alarms.

### 8.2 Troubleshooting

1. I cannot select the mode that I need.
  - a. Ensure the mode has been unlocked, see *Mode Select Options*, page 27.
2. The device won't power on.
  - a. Check mains power is connected to the device, and the standby light is on
  - b. Ensure the battery is charged, if using battery power
  - c. Send device for service
3. The front switch isn't working
  - a. Ensure an MI-E (cough) mode is selected
  - b. Test function by connecting a hand control
  - c. Send device for service
4. Set pressure is not reached
  - a. Ensure correct breathing circuit is attached
  - b. Check patient interface and fit
  - c. Send device for service
5. Internal battery will not charge
  - a. Check mains power connection and the standby light is on
  - b. Send device for service

## 9 Technical Specifications

### 9.1 Parameters Specifications

Setting/Value	Range/Performance
Cough Modes	<ul style="list-style-type: none"><li>• Manual Mode</li><li>• Basic Auto Mode</li><li>• Program Auto Mode</li></ul>
Device Modes	<ul style="list-style-type: none"><li>• Clinical (unlocked)</li><li>• Home (locked)</li></ul>
Insufflation Pressure	3 to 70 cmH <sub>2</sub> O Resolution 1 cmH <sub>2</sub> O Tolerance: ± 5cmH <sub>2</sub> O
Exsufflation Pressure	-3 to -70 cmH <sub>2</sub> O Resolution 1 cmH <sub>2</sub> O Tolerance: ± 5cmH <sub>2</sub> O
Insufflation time (Ti)	0.5 – 5.0 seconds Resolution 0.1 second Tolerance ± 0.25 seconds
Exsufflation time (Te)	0.5 - 5.0 seconds Resolution 0.1 second Tolerance ± 0.25 seconds
Pause time	0.0 - 9.0 seconds (mode dependent) Resolution 0.1 second Tolerance ± 0.25 seconds
Oscillation Frequency	0 – 20 Hz Resolution 1 Hz
Oscillation amplitude	0 - 10 cmH <sub>2</sub> O Resolution 1 cmH <sub>2</sub> O
Measurable Flow	0 - 500 l/min Resolution 1 L/m
SpO <sub>2</sub>	70 - 100% Tolerance ± 2%. No motion or flex sensor
Pulse Rate	25 – 240 BPM Tolerance ± 3 digits. No motion or flex sensor

### 9.2 Electrical Information

Electrical Feature	Specifications
AC Voltage Source	100 to 240 V AC, tolerance +10%/-20%, 50 to 60 Hz, max 260 W
Type of protection against Electric Shock	Class II
Degree of protection against Electric Shock	Type BF Applied Part

Electrical Feature	Specifications
Ingress Protection Rating	Ingress Protection rating: IP22
Mode of Operation	Continuous

### 9.3 Alarm Sound Specifications

Medium and low priority Alarm sound

Alarm	Sound Pressure Level	Indication
Medium Priority Audible Alarm	65 dB(A)	± 4 dB(A) Measured at 1 m
Low Priority Audible Alarm	58 dB(A)	± 4 dB(A) Measured at 1 m

### 9.4 Environmental Operating Conditions

Environmental Conditions	Specifications
Operating Temperature Range	5 to +40°C (41 to 104°F)
Storage and Transport Temperature	-20 to +60°C (-4 to +140°F)
Applied Parts Maximum Operating Temperature	+43°C (109.4°F)
Ambient Pressure Range	700 hPa to 1,060 hPa
Humidity	15% to 90%, non-condensing

Sound Level	Specification
Sound level at 70 cmH <sub>2</sub> O in Manual Mode	Less than 74 dB(A) Measured at 1 m

Ingress Protection	Explanation
IP 22	Solid particle protection: Hazardous parts are protected from touch by fingers and by objects greater than 12 mm. Liquid ingress protection: The protection withstands dripping water less than 15 degrees from vertical. The ingress protection has been tested by water drips equivalent to 3mm rain/minute for 10 minutes (2.5 minutes for each tilting direction)

### 9.5 Dimensions

Dimensions	Specifications
W x H x D	285 x 285 x 195 mm
Weight	3.75 kg (without internal battery)
Patient air outlet	22 mm male, 15 mm female conical standard connector

## 9.6 Emissions and Immunity Declaration

### 9.6.1 Clearo Essential Performance

The Clearo will deliver therapeutic treatment via the patient-connection port (outlet) at the set pressure within the published accuracy limits.

Under the immunity test conditions of IEC 60601-1-2 4<sup>th</sup> Edition, the following allowances are acceptable:

- If the SpO<sub>2</sub> sensor accessory is connected, the Clearo will provide SpO<sub>2</sub> readings within its published accuracy specifications or, indicate abnormal operation. Any temporary degradation of SpO<sub>2</sub> performance following transient immunity test exposure shall recover from any disruption within 30 seconds.

Additionally, the following shall not be allowed:

- Permanent damage or unrecoverable loss of function
- Changes in programmable parameters or settings
- Reset to default settings
- Change of operating mode
- Initiation of unintended operation, or change of operation

### 9.6.2 Compliance of Standards

#### Safety Standards

- IEC EN 60601-1
- IEC EN 60601-1-1
- IEC EN 60601-1-2
- IEC EN 60601-1-6
- IEC EN 60601-1-8
- IEC EN 60601-1-11
- IEC ISO 80601-2-61

### 9.6.3 Electromagnetic Immunity

The Clearo is intended for use in the electromagnetic environment specified below. The user of the device should ensure it is used in such an environment.

Immunity Test	Compliance Level	Electromagnetic Environment - Guidance
Electrostatic Discharge (ESD) IEC 61000-4-2	±8 kV contact ±15 kV air	The relative humidity should be at least 5 %.
Electrical fast Transient/burst IEC 61000-4-4	±2 kV for power supply lines ±1 kV Not applicable for input/output lines	Mains power quality should be that of a typical commercial, hospital and residential environment.
Surge IEC 61000-4-5	±1 kV line to line	Mains power quality should be that of a typical commercial, hospital and residential environment.
<i>UT</i> is the mains voltage prior to application of the test level. [1] Applicable only to home healthcare		

Immunity Test	Compliance Level	Electromagnetic Environment - Guidance
Power frequency (50/60 Hz) magnetic field IEC 61000-4-8	30 A/m	Power frequency magnetic fields should be at levels characteristic of a typical location in a typical commercial, hospital and residential environment.
Radiated fields in close proximity IEC 61000-4-39	30kHz, 8A/m <sup>[1]</sup> 134.2kHz, 65A/m 13.56MHz, 7.5A/m	RF transmitters used in close-proximity should emit electromagnetic energy at levels that are characteristic of a typical location in a typical commercial, hospital and residential environment.
Voltage dips, short interruptions, and voltage variations on power supply input lines IEC 61000-4-11	0% UT, 0.5 cycle (multiple phase analysis); 0% UT, 1 cycle; 70% UT, 25/30 cycles (50/60 Hz); 0% UT, 250/300 cycles (50/60 Hz);	Mains power quality should be that of a typical commercial, hospital and residential environment. If the user of the Clearo requires continued operation during power mains interruptions, it is recommended that the unit be powered from an uninterruptible power supply.
<p>UT is the mains voltage prior to application of the test level. [1] Applicable only to home healthcare</p>		

### WARNING!



Portable RF communications equipment (including peripherals such as antenna cables and external antennas) should be used no closer than 30 cm (12 inches) to any part of the Clearo, including cables specified by the manufacturer. Otherwise, degradation of the performance of this equipment could result.

Immunity Test	IEC 60601 Test Level	Recommended Separation Distance
Conducted RF IEC 61000-4-6	$3 V_{rms}$ 150 kHz to 80 MHz	$d=1.2*\sqrt{P}$ m at 150 kHz to 80 MHz
Radiated RF IEC 61000-4-3	10 V/m 80 MHz to 2.7 GHz	$d= 1.2*\sqrt{P}$ m at 80 MHz to 800 MHz $d= 2.3*\sqrt{P}$ m at 800 MHz to 2.5 GHz <b>Equation description:</b> P is the maximum output power rating of the transmitter in watts (W) according to the transmitter manufacturer and d is the recommended separation distance in metres (m). Field strengths from fixed RF transmitters, as determined by an electromagnetic site survey <sup>a</sup> , should be less than the compliance level in each frequency range <sup>b</sup> . Interference may occur in the vicinity of equipment marked with this symbol: 

## NOTE

- At 80 MHz and 800 MHz, the higher frequency range applies.
- These guidelines may not apply in all situations. Electromagnetic propagation is affected by absorption and reflection from structures, objects, and people.

a) Field strengths from fixed transmitters, such as base stations for radio (cellular/cordless) telephones and land mobile radios, amateur radio, AM and FM radio broadcast and TV broadcast cannot be predicted theoretically with accuracy. To assess the electromagnetic environment due to fixed RF transmitters, and electromagnetic site survey should be considered. If the measured field strength in the location in which the ME equipment is used exceeds the applicable RF compliance level above, the ME equipment should be observed to verify normal operation. If abnormal performance is observed, additional measures may be necessary, such as re-orientating or relocating the equipment.

b) Over the frequency range 150 KHz to 80 MHz, the field strengths should be less than 10 V/m.



### 9.6.4 Electromagnetic Emission

The Clearo is intended for use in the electromagnetic environment specified below. The user of the device should ensure it is used in such an environment.

Emissions Test	Compliance	Electromagnetic Environment - Guidance
RF emissions CISPR 11	Group 1	The Clearo uses RF energy only for its internal function. Therefore, its RF emissions are very low and are not likely to cause any interference in nearby electronic equipment.
RF emissions CISPR 11	Class B	The Clearo is suitable for use in all establishments, including domestic establishments and those directly connected to the public low-voltage power supply network that supplies buildings used for domestic purposes
Harmonic emissions IEC 61000-3-2	Class A	
Voltage fluctuations/ flicker emission IEC 61000-3-3	Complies	

**9.6.5 Frequencies of portable and mobile transmitters for which the recommended separation distance is 30 cm (12 inches)**

Band (MHz)	Service	Immunity test level (V/m)
380-390	Tetra 400	27
430-470	GMRS 460; FRS 460	28
704-787	LTE Band 13, 17	9
800-960	GSM 800/900; TETRA 800; iDEN 820; CDMA 850; LTE Band 5	28
1,700-1,990	GSM 1800; CDMA 1900; GSM 1900; DECT; LTE Band 1,3,4,25; UMTS	28
2,400-2,570	Bluetooth; WLAN 802 11 b/g/n; RFID 2450; LTE Band 7	28
5,100-5,800	WLAN 802 11 a/n	9

**9.6.6 Recommended separation distances between portable and mobile RF communications equipment and the Clearo**

The Clearo is intended for use in an electromagnetic environment in which radiated RF disturbances are controlled. The customer or the user of the Clearo can help prevent electromagnetic interference by maintaining a minimum distance between portable and mobile RF communications equipment (transmitters) and the Clearo as recommended below, according to the maximum output power of the communications equipment.

Rated Maximum Output Power of Transmitter (W)	Separation Distance According to the Frequency of Transmitter (M)		
	150 kHz to 80 MHz $d=1.2*\sqrt{P}$ (meters)	80 MHz to 800 MHz $d=1.2*\sqrt{P}$ (meters)	800 MHz to 2.5 GHz $d=1.2*\sqrt{P}$ (meters)
0.01	0.12	0.12	0.23
0.1	0.38	0.38	0.73
1	1.2	1.2	2.3
10	3.8	3.8	7.3
100	12	12	23

For transmitters rated at a maximum output power not listed above, the recommended separation distance  $d$  in metres (m) can be estimated using the equation applicable to the frequency of the transmitter, where  $P$  is the maximum output power rating of the transmitter in watts (W) according to the transmitter manufacturer.

**NOTE**

- At 80 MHz and 800 MHz, the separation distance for the higher frequency range applies.

These guidelines may not apply in all situations. Electromagnetic propagation is affected by absorption and reflection from structures, objects, and people.



### 9.6.7 Recommended separation distances between external power conductors and the Clearo

Rated Maximum Current in Conductor (A)	Separation Distance (M)
	50-60 Hz $d = I/2\pi H = I/188$
1	0.005
10	0.05
30	0.16

For conductors rated at a maximum current not listed above, the recommended separation distance  $d$  in metres (m) can be estimated using the equation  $d = I/2\pi H$ , where  $I$  is the maximum current rating of the conductor in amperes (A) according to the transmitter manufacturer;  $H$  is the Clearo immunity compliance level to electromagnetic fields in the 50-60 Hz frequency span (30 A/m).



#### **WARNING!**

Portable RF devices (e.g. mobile phones) should be used no closer than 30 cm (12 inches) to any part of the ME Equipment, including any cables.

# 10 Accessories

Only use accessories recommended by Breas Medical AB. Breas Medical cannot guarantee the performance and safety for the use of other accessories with the Clearo.

Accessory equipment connected to the analogue and digital interfaces must be certified according to the respective IEC standards (e.g. IEC 60950 for data processing equipment and IEC 60601-1 for medical equipment). Furthermore, all configurations must comply with the valid version of the system standard IEC 60601-1-1. Anybody who connects additional equipment to the signal input part or signal output part is configuring a medical system and is therefore responsible for ensuring the system complies with the requirements of the valid version of the system standard IEC 60601-1-1. If in doubt, consult the technical service department or your local representative.

## 10.1 Package Content

The Clearo may include the following components.

Some components are optional accessories that may not be sent with your device from the referring clinician or home care provider, please see 10.2 *Optional Accessories*, page 61.

- Clearo Device
- Patient Circuit, including bacterial filter
- Carrying Bag
- AC Power Cord
- Air Inlet Filters
- User Manual

## 10.2 Optional Accessories

Accessory	Article Number
Fine Air Inlet Filters (white)	009065
Coarse Air Inlet Filters (grey)	009066
Carry Bag	009067
AC Mains Cable	IEC type F (e.g. EU): 008383 IEC type G (e.g. U.K.): 009074 IEC type I (AU): 008370 IEC type J (CH): 009205 JIS 8303 (JP): 009704 NEMA 1-15 (US): 010080
Hand Control	008279
Patient Circuit Americas (10 pcs)	010466
Bacterial Filters	008169
SpO <sub>2</sub> Sensor Module	006369
SpO <sub>2</sub> Sensor Adult	006589
SpO <sub>2</sub> Sensor Paediatric	006590
Internal Battery	008283
Memory Card	006705

**CAUTION!**

Use with other manufacturer's accessories or non-approved Breas accessories supplied or recommended by Breas may cause the device to malfunction.

# A Patient Settings

This page can be copied and used for noting the patient's settings.

Patient	Date
Settings made by	Clinic
Patient Circuit	Mode
Ins pressure	Ins trigger
Exs pressure	Ti
Ramp	Te
Ins Breaths	Step
Pause	Recruitment breaths
Treatment Cycles	Oscillation frequency
Insufflation amplitude	Exsufflation amplitude

Notes:

## B Glossary of Abbreviations and Terms

Basic Auto Mode	Provides an Insufflation, followed by an exsufflation and a pause, may be repeated in multiple cycles, and is a mode of therapy within MI-E
BPM	Breaths Per Minute
Carer	Persons caring for the patient e.g. Nurse or Family/Friend
Cycle	A single run of a set number of insufflations, followed by an Exsufflation
Doctor	Prescribing Health Care Professional e.g. Physician, Physiotherapist
Expiratory	Exhale stage of a respiratory cycle
Exsufflation	The negative pressure delivered by the device
Inspiratory	Inhale stage of a respiratory cycle
Insufflation	The positive pressure delivered by the device
Insufflation Estimated Tidal Volume	Indicates the estimated lung volume during insufflation (ml)
Mechanical Insufflation-Exsufflation (MI-E)	Mechanical insufflation-exsufflation therapy. The device delivers a positive pressure breath to inflate the lungs similar to taking a deep breath . This is immediately followed by a rapid shift to negative pressure, which pulls air out of the lungs quickly, mimicking the forceful exhalation of a cough.
Patient	Persons prescribed the device for medical care/treatment
Peak Cough Flow (PCF)	A measurement of the maximum speed of expiration during a cough.
Synchrony Beep®	The Synchrony Beep is designed to assist both the patient and therapist/carer to time the cough and/or manual treatment with the exsufflation, to help improve synchrony
Treatment	A treatment is a set number of cycles of the prescribed settings, at the frequency stated by the prescribing physician/physiotherapist/doctor
TreatRepeat®	TreatRepeat® is the ability to save a manual treatment performed into a pre-set program, therefore reducing time for titration as well as enhancing patient synchrony
User	Main user of the device. Usually the carer, or the patient themselves

# Index

## A

AC connection	20
air inlet	17
air inlet filters, cleaning and replacing	49
alarm function	36
alarm indication	36
alarm log	25
alarm PIC communications fault	43
alarm reset	36
alarm, alarm PIC communications fault	43
alarm, blower control fault	46
alarm, blower control fault and/or blower fault	46
alarm, blower current fault and/or blower speed fault	45
alarm, blower driver fault	42
alarm, blower fault	44
alarm, blower speed fault	44–45
alarm, high pressure	37
alarm, internal module communications fault	43
alarm, low alarm battery	41
alarm, low battery power	39
alarm, mains power fault	42
alarm, over temperature	41
alarm, power fail	37
alarm, power source changed	37
alarm, pressure measurement fault	38
alarm, pressure sensor fault	38
alarm, SpO <sub>2</sub> sensor disconnected	39
alarm, valve current fault	45–46
alarm, valve drive fault	43, 47
alarm, valve position fault	44, 47
alarm, valve zero fault	42
alarm, volume	27
alarm, battery exhausted	38

## B

Batteries	32
battery exhausted, alarm	38
blower control fault	46
blower control fault and/or blower fault	46

blower current fault and/or blower speed fault	45
blower driver fault	42
blower fault	44
blower speed fault	44–45
breaths, recruitment	30
brightness	27

## C

checks	50
cleaning, exterior	49
compliance data, transfer	34
compliance summary	25
contact information	9
contraindications	7

## D

Data, transfer	34
dimensions	55
disposal	52

## E

electrical safety	12
electromagnetic emission	58
electromagnetic immunity	56, 59
EMC, separation distances	59–60
environmental safety	12
essential performance	56

## F

filter housing	17
filter, cleaning and replacing	49
front panel	15

## H

high pressure, alarm	37
----------------------	----

## I

icons	5, 15, 17, 23
internal battery health bad, message	41
internal module communications fault	43

## L

language .....	27
low alarm battery, alarm .....	41
low battery power, alarm .....	39

## M

Mains connection .....	20
mains power fault .....	42
menu button .....	25
message, internal battery health bad .....	41
message, SPO <sub>2</sub> connected .....	40
message, treatment has finished .....	40
message, treatment not saved .....	40
message, treatment too long .....	39
mode select options .....	27
mode, select .....	28
multiple use .....	50

## O

on/off button .....	15
operating conditions .....	55
over temperature, alarm .....	41

## P

parameters, specifications .....	54
patient air outlet .....	16
patient circuit, connect .....	22
placement .....	20
power connector .....	17
power fail, alarm .....	37
power source changed, alarm .....	37
pressure measurement fault, alarm .....	38
pressure sensor fault, alarm .....	38
profiles .....	28

## R

recruitment breaths .....	30
reset .....	25

## S

screen, brightness .....	27
SD memory card slot .....	16
separation distances, EMC .....	59–60
service .....	51
service life .....	53

SPO <sub>2</sub> connected, message .....	40
SpO <sub>2</sub> connection .....	16
SpO <sub>2</sub> sensor .....	31
SpO <sub>2</sub> sensor disconnected, alarm .....	39
standards .....	56
start up check .....	21
start/stop button .....	15
storage .....	51
symbols .....	5, 15, 17
symbols, on screen .....	23
synchro beep .....	27

## T

transport .....	51
travelling .....	53
treatment has finished, message .....	40
treatment not saved, message .....	40
treatment too long, message .....	39
treatment, preview .....	31
treatment, start and stop .....	29
troubleshooting .....	53

## U

USB connection .....	16
User data .....	32
user preferences .....	25

## V

valve current fault .....	45–46
valve drive fault .....	43, 47
valve position fault .....	44, 47
valve zero fault .....	42

## W

waveforms .....	31
-----------------	----